

Base Office Drawer Cabinet

R3 18 W - 29 T - 20 D

Note: Sizes Can Be Ordered That Are Different Than What Is Above, Call For Details.

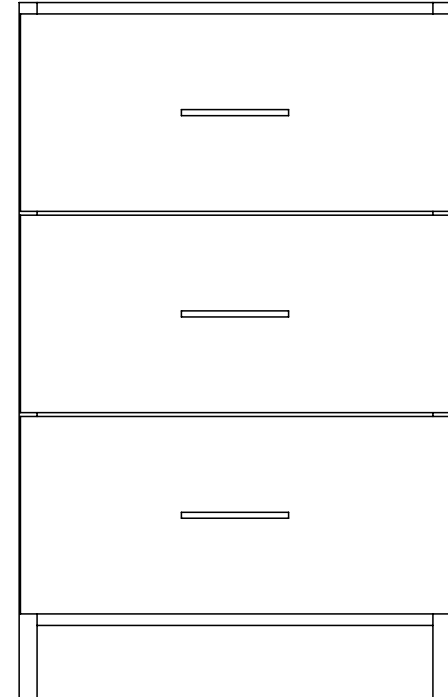

Name:	Address:	ARCHITECTURAL CABINETRY <hr/> Murphybed, Panelbed, Home Office & Closets 790 Big Tree Drive Longwood, FL 32750 www.panelbed.com 407-331-0600 Fax: 407-331-1800
Phone:	Address:	
Job: office instructions base r3	City: _____, Zip: _____	
Handle:		

3 Drawer Base Cabinet

18" W x 29" T x 20" D Base "R-3"

Quan	Part	Width	Length
3	Drawer Box Back	5 3/16	15 1/4
3	Drawer Box Bottom	15 1/4	19 5/8
1	Deck	20	16 1/2
3	Door Slab	8 1/4	17 7/8
1	Finished Left End	20	29
1	Finished Right End	20	29
1	Front Toe	3 1/16	16 1/2
1	Top	20	16 1/2

**

**

Note: (**)The Drawer Box Back & Bottom are always in white 5/8" material.

LABEL INFORMATION

THIS PAGE IS FOR UNDERSTANDING THE LABEL ON EACH PART, THIS ALLOWS YOU TO KNOW WHAT INFORMATION THIS PART HAS AND HOW IT PERTAINS TO YOUR ORDER.

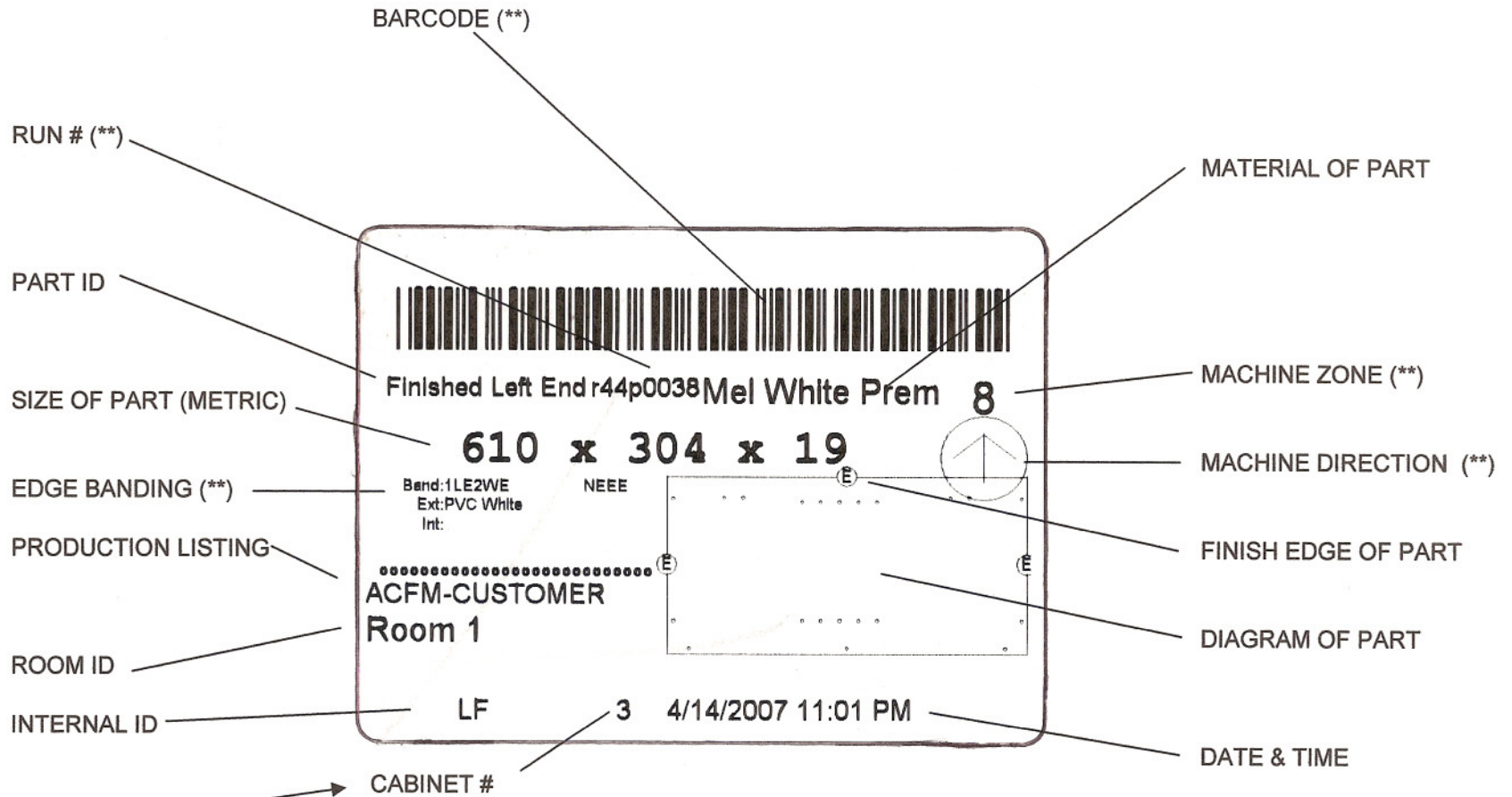

***** WE RECOMMEND THE 1ST THING YOU DO, IS TO SORT ALL YOUR PARTS BY (CABINET #) *****
THIS ENABLES YOU TO SEE ALL THE PARTS FOR EACH CABINET AND MAKES ASSEMBLE EASIER

ANY NOTATION WITH (**) IS INFORMATION USED IN FOR FACTORY AND WOULD NOT HELP YOU

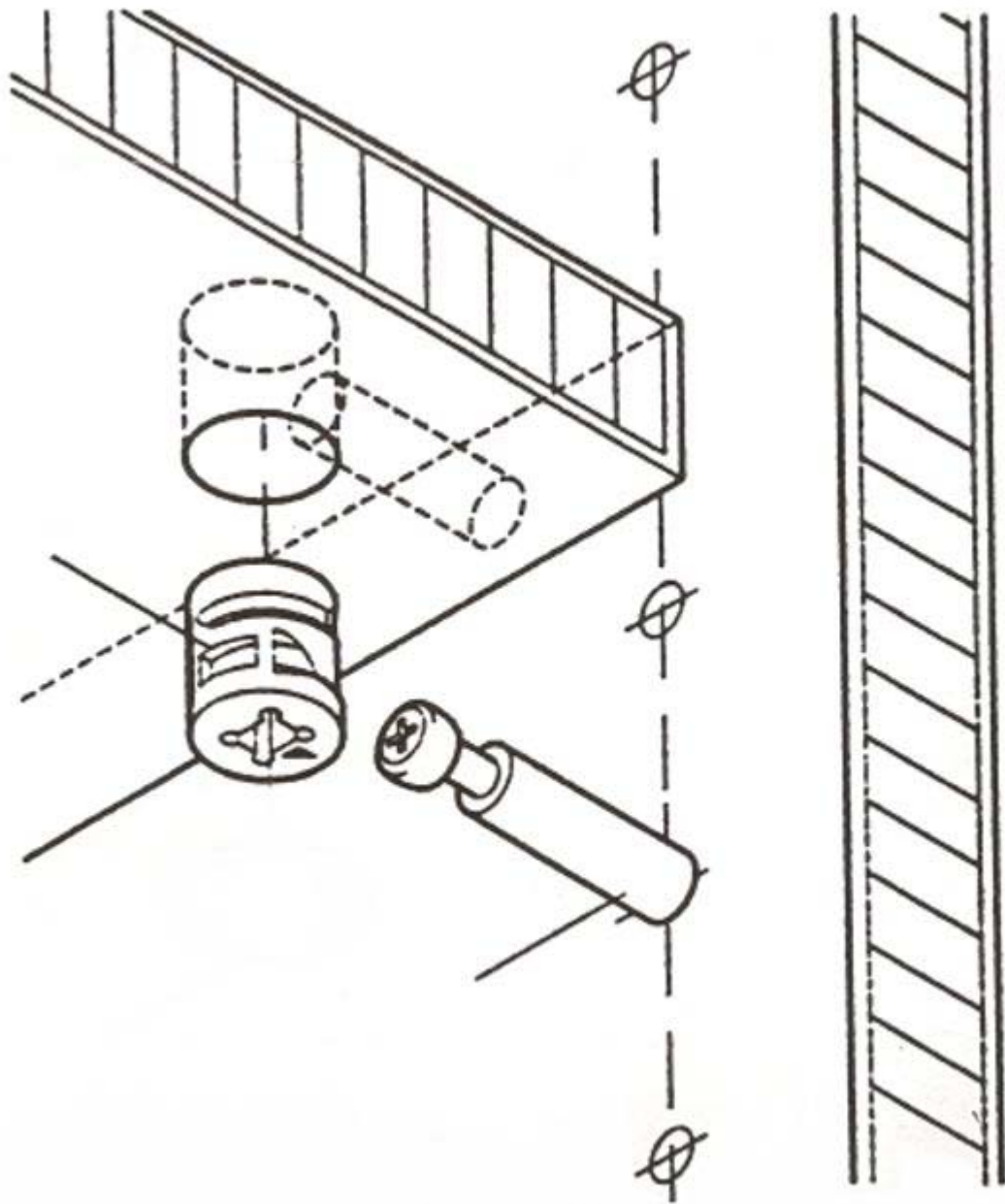

Typical Pin & Cam Installation

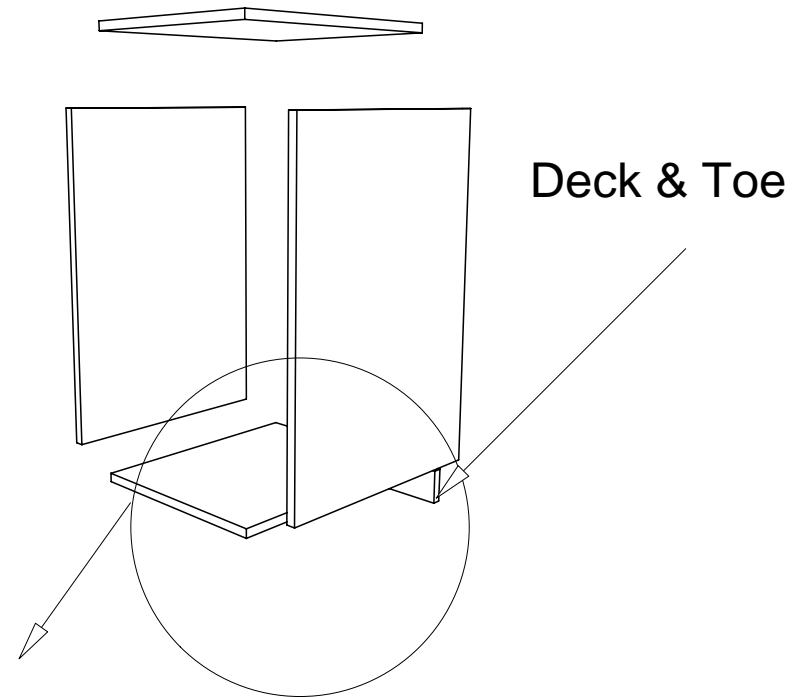
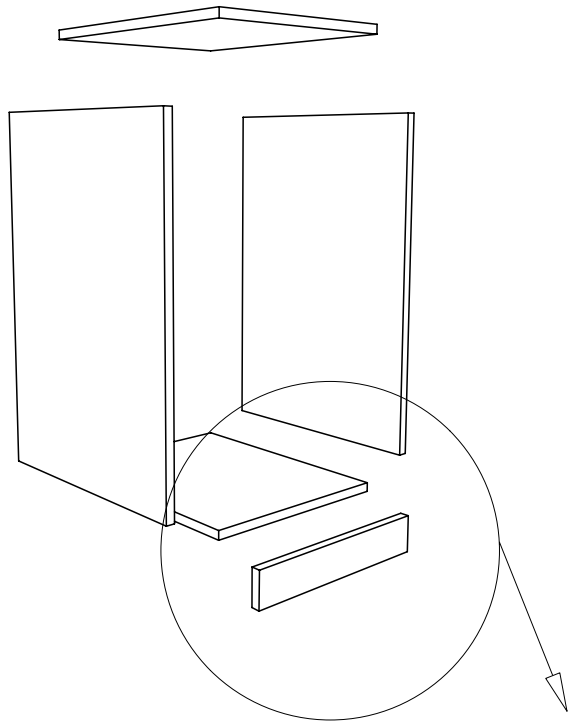

When Assembling The Cabinet Parts, The 1st Thing Is To Assemble The Bottom Of The Cabinet. You Will Connect The Deck & Toe Together.

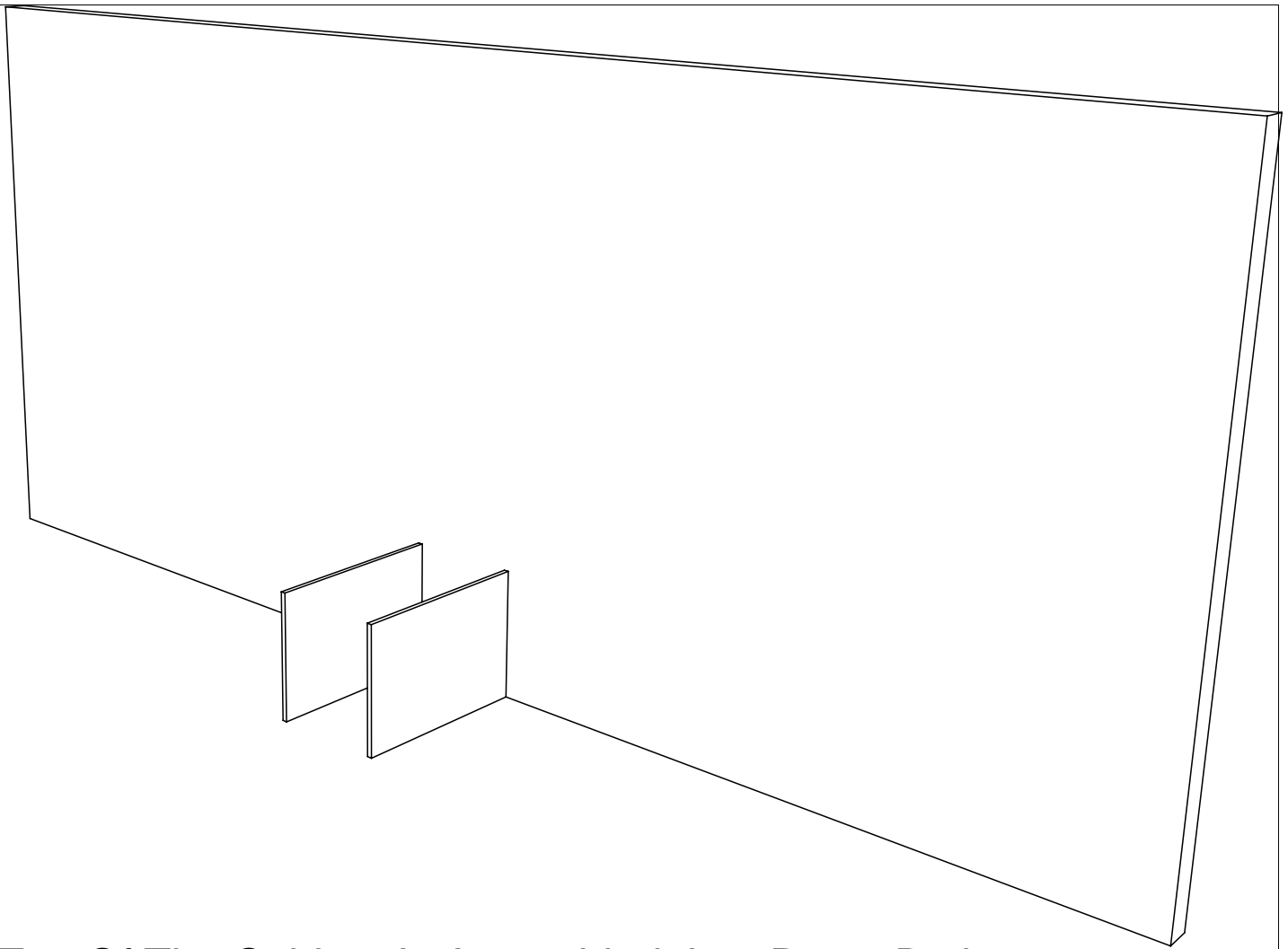

Now That The Top Of The Cabinet Is Assembled, Lay Down Both Sides Of The Cabinet, You Want The Front Face Touching The Floor. Install All Pins, Hinges Plates & Drawer Guides Into The Sides At This Point.

Note: Place Cardboard Or A Blanket Down On The Floor, Before Laying Cabinet Sides Down On The Floor.

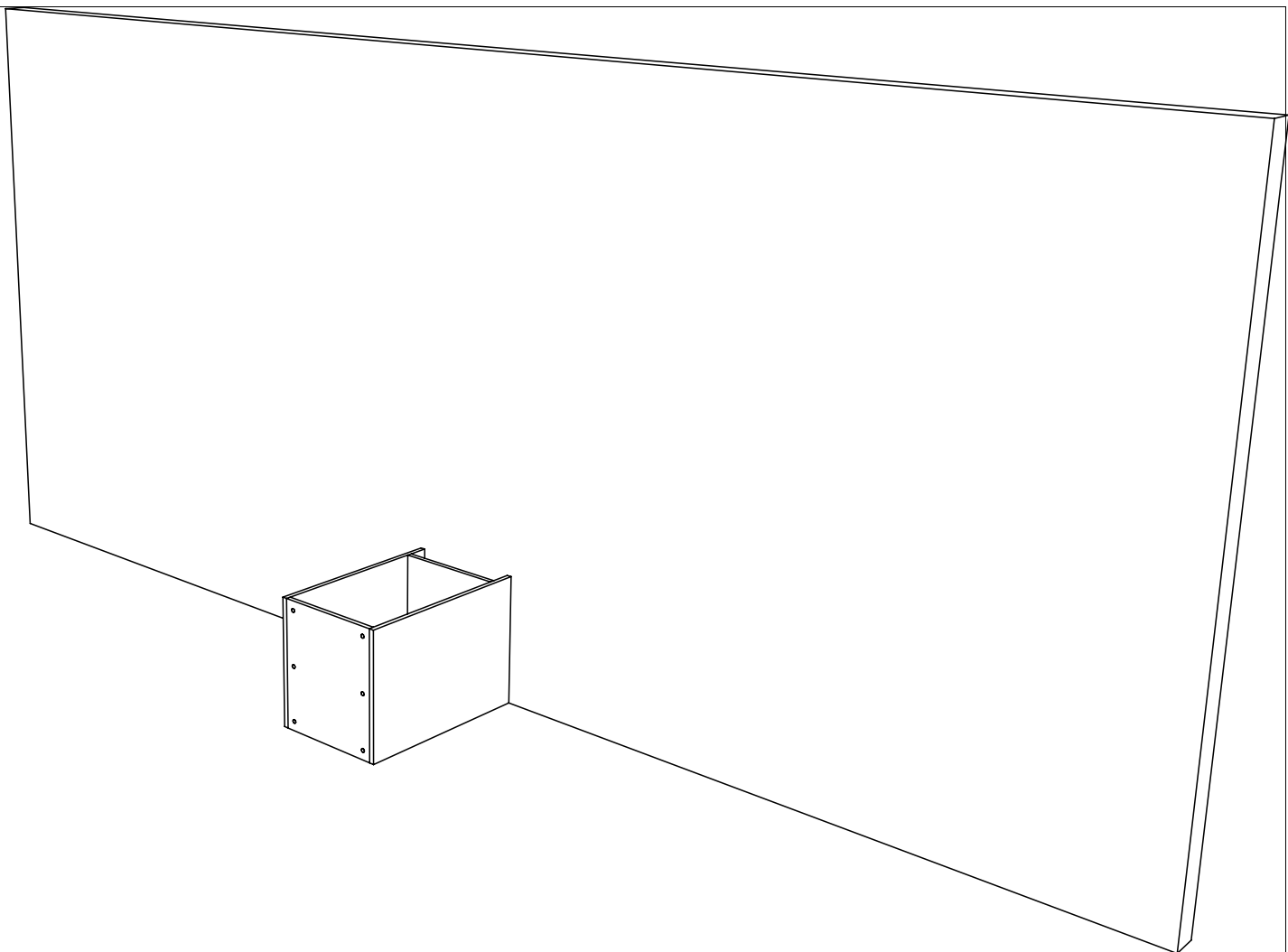

Place The Top and Bottom Deck Between The 2 Sides And Slide On The Pins, Do Not Tighten The Pins & Cams Until both Are Into Position And Then Tighten Both Of Them.

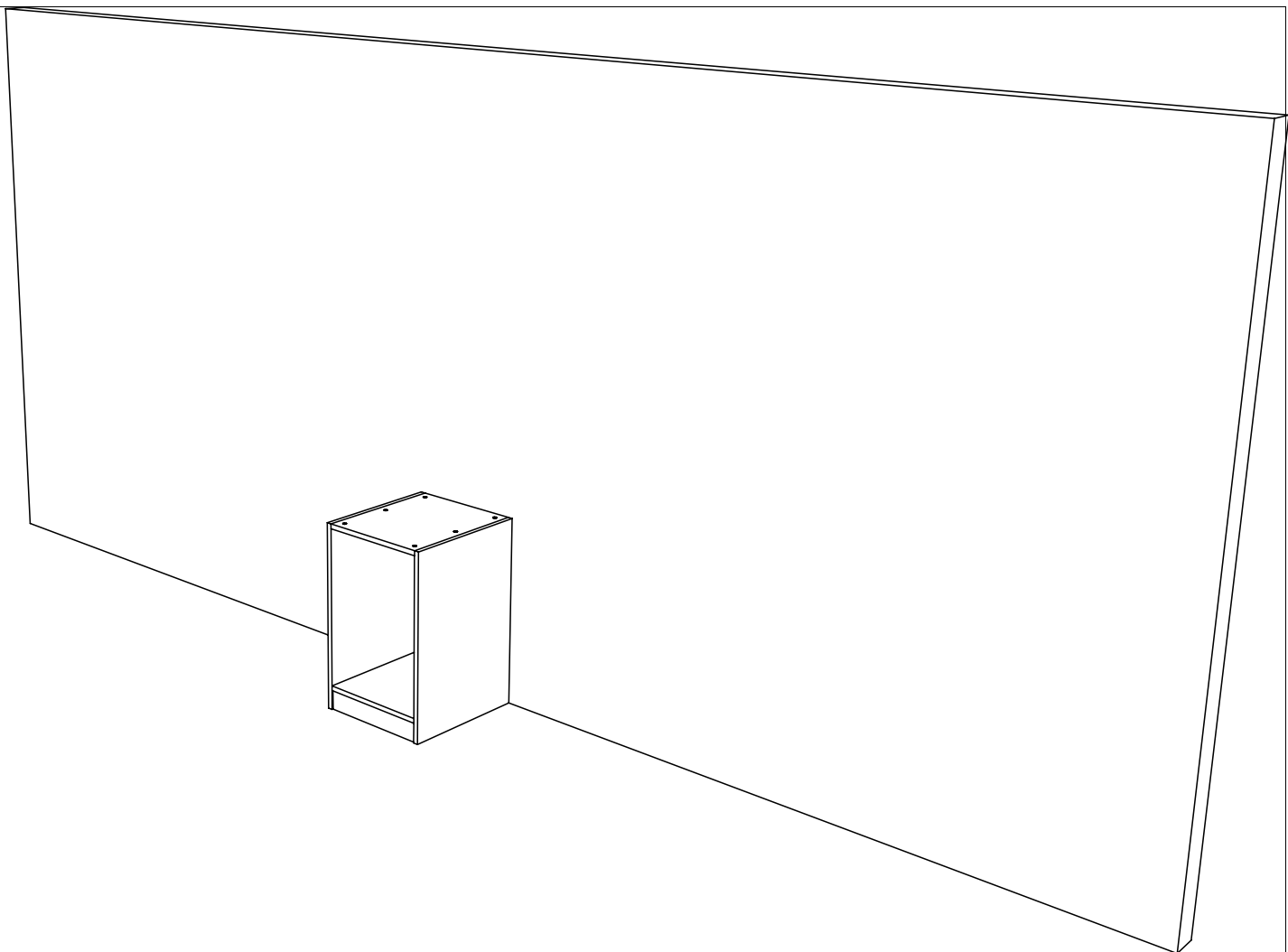

After Tightening The Pins & Cams, Then Stand Up The Cabinet To The Wall.
Move The Cabinet Into The Exact Location That You Want It To Be Along
The Wall.

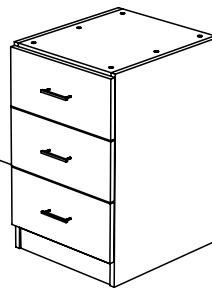

Now That The Cabinet Is Assembled, You Are Ready To Start The Assembly Of The Drawers.

Use 1.5 x 1.5 "L" Brackets & Screws

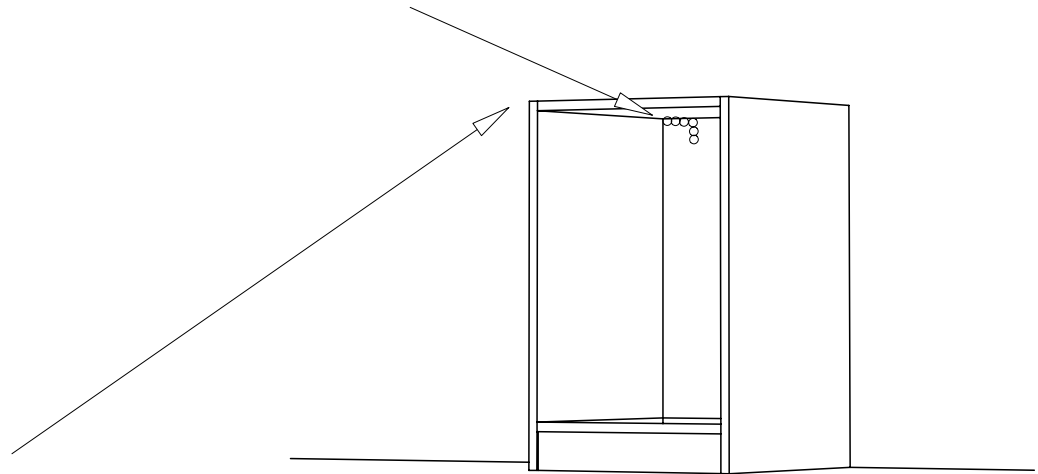

Note: Use 2 Screws Per Stud
Best If Studs Are On 16" Centers

Note: Base Cabinet Has To Be Plumb & Level, Before Securing It To The Wall.

Now That The Base Cabinet Is Standing Up And Is In The Correct Location, You Will Need To Secure It To The Wall. Depending On Your Wall Construction, You Will Need To Choose The Type Of Fastener To Safely Secure The Base Cabinet To The Wall

--- Typical Wall Construction ---

2x4 Wood Stud (Use 2 1/2" Drywall Screws)
Concrete (Use 2" Tap Con Screws)

Drawer components

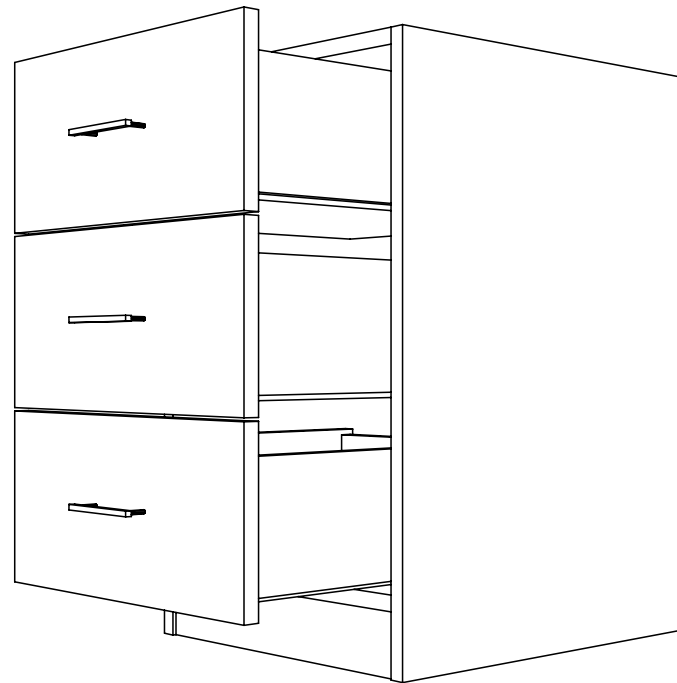
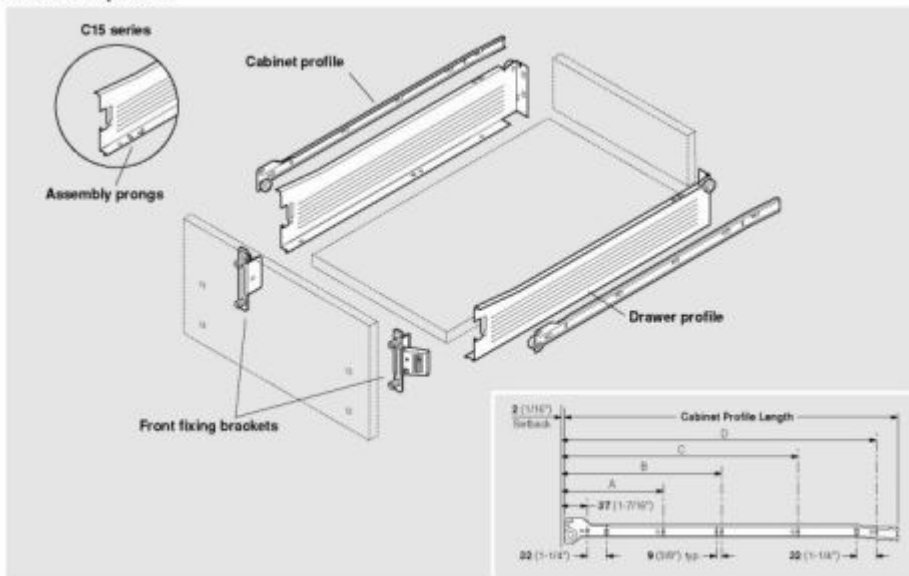

Metabox Drawer Box Assembly & Front for Large Interior Drawer box

Architectural Cabinetry & Furniture Mfg. Inc.

Longwood, FL 32750

www.PanelBed.com

888-Diy-Beds (888-349-2337)

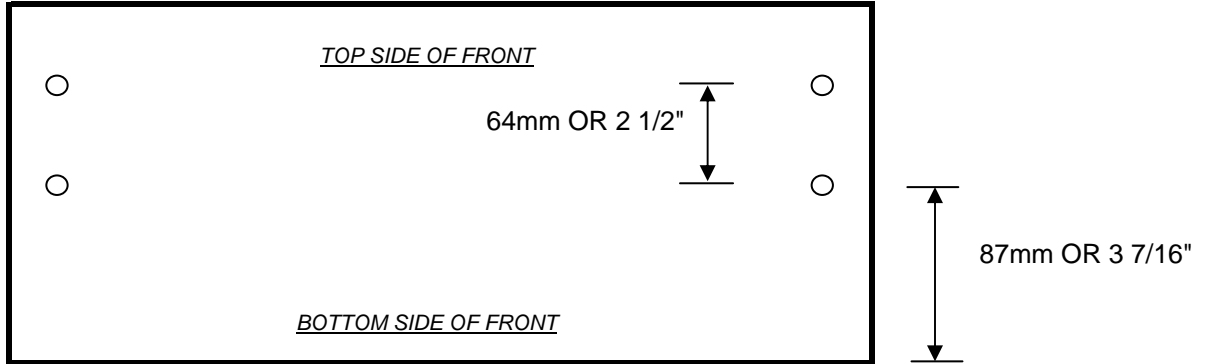

All unassembled parts including the drawer front



All unassembled parts for the complete drawer box assembly



Both prongs are inserted into the back holes and the front hole will be for a euro screw to hold the bottom in place



Place euro screw in front hole to secure the bottom



After both sides are screwed into place and are secure add back



Now drawer box assembly is complete and ready to attach the front



Insert Fixing Brackets into drawer front and drive in screws to secure them.



The drawer front is ready to attach to drawer assembly.



Place front onto drawer box assembly with clip in the open position.



With your fingers, just push the clip to close and secure the front to the drawer box assembly.



Attach the runner inside the cabinet for drawer box assembly to roll into.