

# Metabox Drawer Box Assembly & Front for Lat File Interior Drawer box

Architectural Cabinetry & Furniture Mfg. Inc.

Longwood, FL 32750

[www.PanelBed.com](http://www.PanelBed.com)

888-Diy-Beds (888-349-2337)

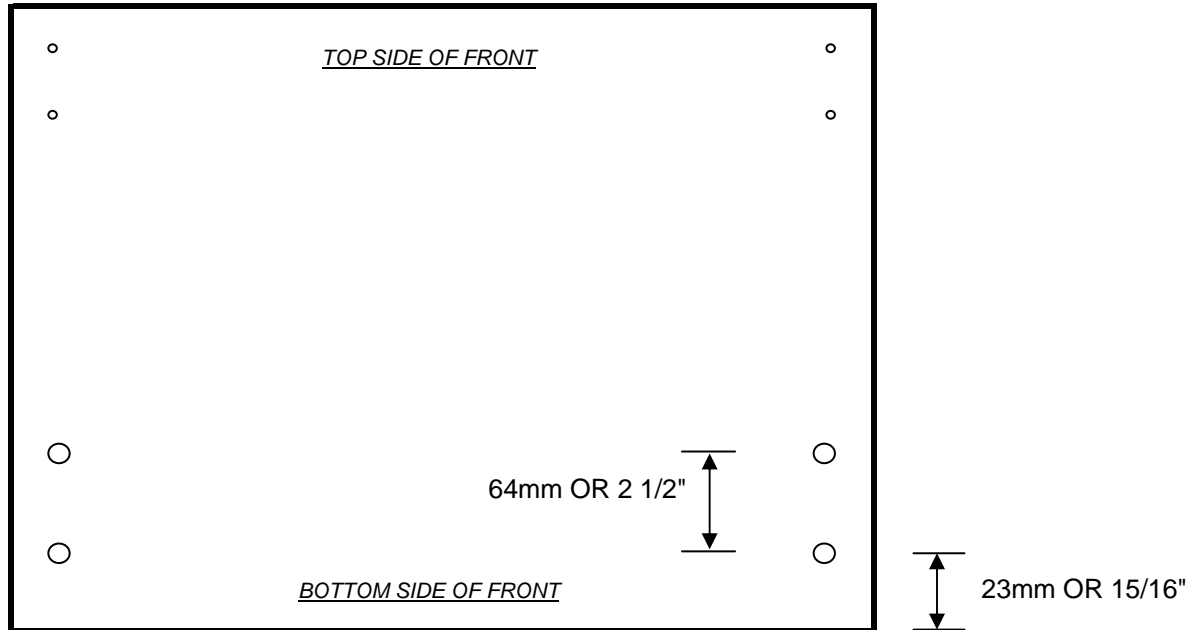

All unassembled parts including the drawer front

This also used for the standard Letter and Legal Drawer Box Assembly.  
The only difference is the drawer width and no Lat Bars are involved.



All unassembled parts for the complete drawer box assembly



Both prongs are inserted into the back holes and the front hole will be for a euro screw to hold the bottom in place



Place euro screw in front hole to secure the bottom



After both sides are screwed into place and are secure add back

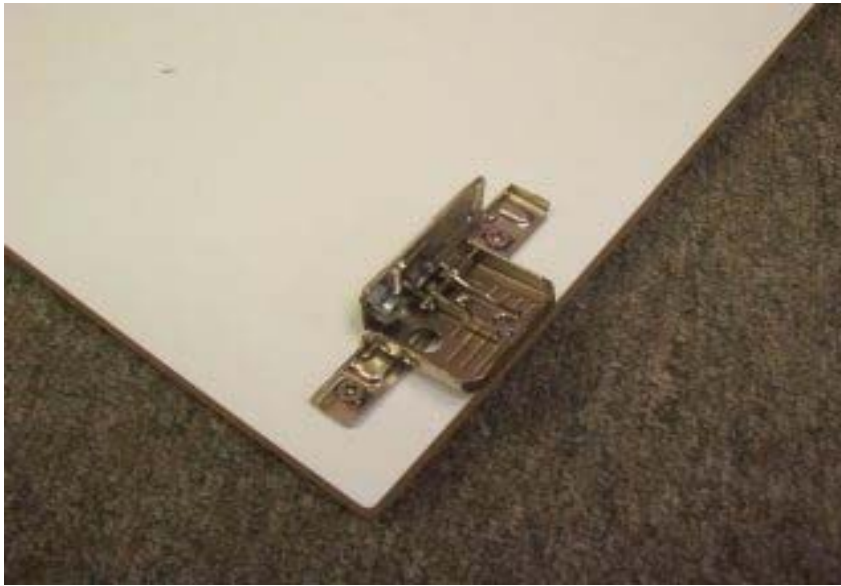

Now drawer box assembly is complete and ready to attach the front

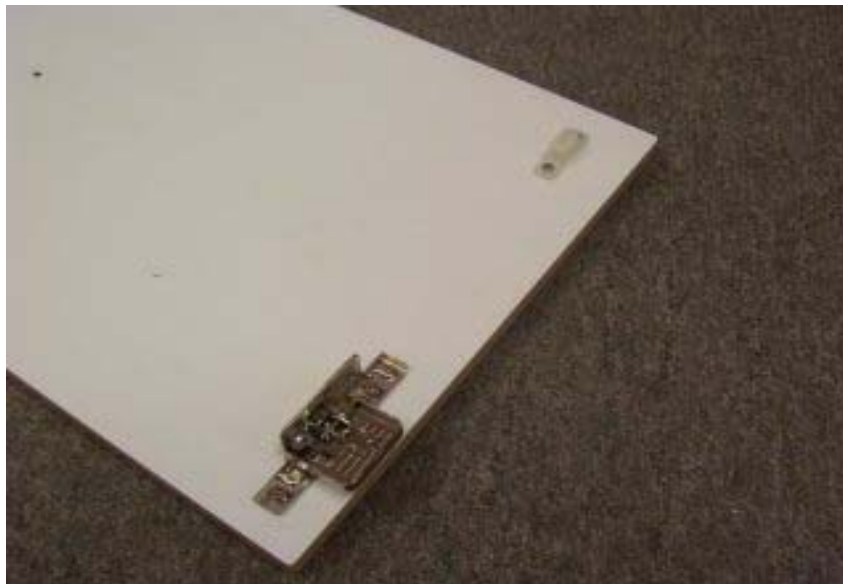

Insert Fixing Brackets & File Brackets into drawer front and drive in screws to secure them.

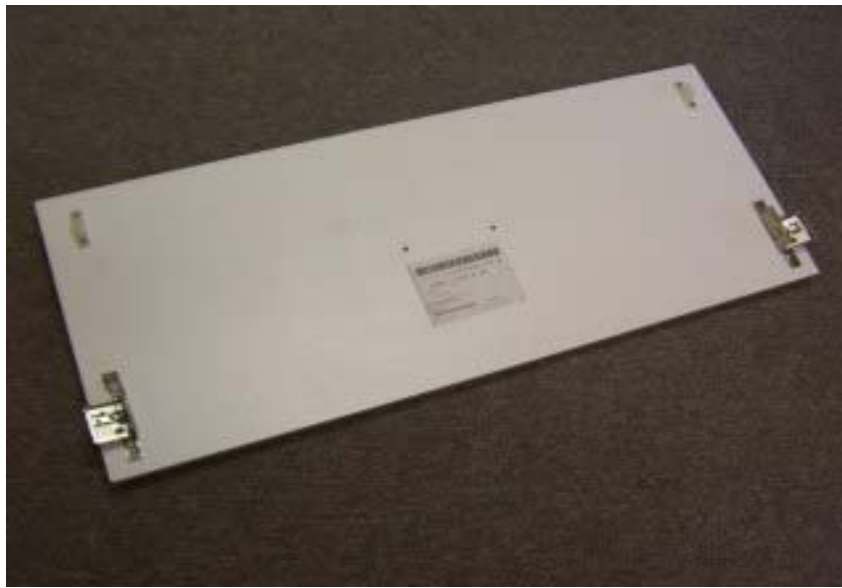

The drawer front is ready to attach to drawer assembly.



Place front onto drawer box assembly with clip in the open position.



With your fingers, just push the clip to close and secure the front to the drawer box assembly.



Insert side file bar into bracket on back of front



Slide bracket cover over bracket after bar is inserted.



Secure side file rail to the back with #6 screw



Drawer Box Assembly is complete and now ready for Lat bars.



Insert the ends on both Lat Bars



Press ends of Lat bars onto the side bars and move to desired position for either Letter or Legal files.



Attach the runner inside the cabinet for drawer box assembly to roll into.